

# 92 Smalley Certificates Awarded

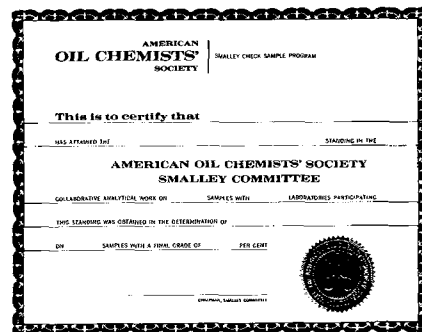

Ninety-two chemists received certificates of proficiency in the Smalley Check Sample Program this spring with the names of winners of first place certificates being announced and certificates awarded during the inaugural luncheon at the 68th Annual Meeting in New York.

For the second consecutive year, Horace J. Keith, laboratory supervisor at Anderson Clayton & Co. in Lubbock, TX, received the Smalley Cup. The cup is given to the chemist with the highest proficiency in the combined determination of moisture, oil, and nitrogen in the Oilseed Meal Series.

Edward R. Hahn, owner of Hahn Laboratories in Columbia, SC, received the 1976-77 R.T. Doughtie Cup for attaining the highest proficiency in analysis of cottonseed.

The Smalley Program this year involved 19 series with 23 separate categories. A total of 332 individual chemists enrolled, participating in a combined total of 818 sample series. There were 6,069 check samples distributed for analysis. The competitive program provides a means for an individual chemist to check his work against the performance of his peers throughout the world.

The 1977-78 program will offer 20 sample series, including vegetable oil for color, and a new combined safflower, sunflower, and rapeseed series.

Certificates of proficiency were awarded to the following individuals in the categories designated:

## Oilseed Meal (15 samples)

### *Combined moisture, oil, and nitrogen determination*

#### First Place:

Horace J. Keith, Anderson Clayton & Co., Lubbock, TX

#### Honorable Mention:

Ronnie W. Fox, Texas Testing Laboratory, Dallas, TX  
Biffle Owen, Planters Manufacturing Co., Clarksdale, MS

E.R. Hahn, Hahn Laboratories, Columbia, SC  
J.E. Williams, Woodson-Tenent Laboratory, Clarksdale, MS  
John Ledin, Woodson-Tenent Laboratories, Des Moines, IA

### *Moisture Determination*

#### First Place:

John Ledin, Woodson-Tenent Laboratories, Des Moines, IA

#### Honorable Mention:

Robert Hein, Dawson Mills, Dawson, MN  
B. Lee Keating, K-Testing Laboratory, Memphis, TN  
J.E. Williams, Woodson-Tenent Laboratory, Clarksdale, MS  
J.P. Henry, Iowa Testing Laboratories, Eagle Grove, IA  
Lela I. Vines, Woodson-Tenent Laboratories, Wilson, AR

## *Oil Determination*

### First Place:

Horace J. Keith, Anderson Clayton & Co., Lubbock, TX

### Honorable Mention

E.R. Hahn, Hahn Laboratories, Columbia, SC  
Ronnie M. Fox, Texas Testing Laboratory, Dallas, TX  
James P. Minyard Jr., Mississippi State Chemical Laboratory, Mississippi State, MS  
John W. Thomas, Superintendence Co., Inc., Kenner, LA  
Carl M. Cater, Texas A&M University, College Station, TX

## *Nitrogen Determination*

### First Place:

Vera Pierce, Plains Cooperative Oil Mill, Lubbock, TX

### Honorable Mention:

Horace J. Keith, Anderson Clayton & Co., Lubbock, TX  
Ronnie M. Fox, Texas Testing Laboratory, Dallas, TX  
Lela I. Vines, Woodson-Tenent Laboratory, Wilson, AR  
Michael L. Valletta, Superintendence Co., New York, NY

## *Crude Fiber Determination*

### First Place:

Paul D. Irwin, Virginia State Chemist, Consolidated Laboratory Services, Richmond, VA.

### Honorable Mention:

Joe G. Bowling, Woodson-Tenent Laboratories, Goldston, NC  
Arlin Van Kley, Land O'Lakes Inc., Sheldon, IA  
Mamdouh H. Abed, Abed Laboratories, Berkeley, CA  
John W. Thomas, Superintendence Co., Inc., Kenner, LA

## **Cottonseed (10 samples)**

### First Place:

Edward R. Hahn, Hahn Laboratories, Columbia, SC

### Honorable Mention:

J.E. Williams, Woodson-Tenent Laboratories, Clarksdale, MS  
Ronnie M. Fox, Texas Testing Laboratory, Dallas, TX  
Biffle Owen, Planters Manufacturing Co., Clarksdale, MS

## **Soybeans (10 samples)**

### First Place:

J.E. Williams, Woodson-Tenent Laboratories, Clarksdale, MS

### Honorable Mention:

Arthur C. McConnell, Woodson-Tenent Laboratories, Memphis, TN  
Thomas J. Moore, Woodson-Tenent Laboratories, North Little Rock, AR  
Robert Hein, Dawson Mills, Dawson, MN

**Peanuts (7 samples)**

First Place:  
John G. Caran, Texas Testing Laboratories, San Antonio, TX

Second Place:  
Edward R. Hahn, Hahn Laboratories, Columbia, SC

**Safflower (7 samples)**

First Place:  
Terry L. Fries, Producers Cotton Oil Co., Fresno, CA

Second Place:  
Mamdouh H. Abed, Abed Laboratories, Berkeley, CA

**Cellulose (10 samples)**

First Place (Tie):  
Ronnie M. Fox, Texas Testing Laboratories, Dallas, TX  
Leon S. Hunter, Pope Testing Laboratories, Dallas, TX

**Drying Oil (6 samples)**

First Place:  
T.M. Marayanan Nair, Charles V. Bacon Laboratories, Inc., Jersey City, NJ

Second Place:  
Robert M. Pierce, Honeymead Products Co., Minneapolis, MN

**Edible Fats (5 samples)**

First Place:  
Keith R. Palm, Swift Edible Oil Co., Chattanooga, TN

Honorable Mention:  
Bert R. Boynton, Swift Edible Oil Co., Fort Worth, TX  
Robert Powell, Safeway Stores, Denison, TX  
Thomas M. McCrory, Humko Products, Memphis, TN  
Daniel C. Esgar, Glidden-Durkee, Joliet, IL

**Tallow & Grease (5 samples)**

First Place:  
Willis L. Price, Lever Brothers Co., Baltimore, MD

Honorable Mention:  
J. MacPherson, Canada Packers, Ltd., St. Boniface, MB  
Paul C. Thionville, Thionville Laboratories, New Orleans, LA  
John W. Thomas, Superintendence Co., Kenner, LA  
Ellsworth L. Hanson, Armour & Co., South St. Paul, MN  
S.E. Farah, Superintendence Co. (Canada), Montreal, Canada

**Corn Aflatoxins (6 samples)**

First Place:  
Dan Blackshear, J.M. Poultry, El Dorado, AR

Second Place:  
Nick Galuzevski, Laura Scudder's Snack Foods, Div. of Pet, Inc., Anaheim, CA

**Cottonseed Aflatoxins (6 samples)**

First Place:  
Warren Truman, Casa Grande Oil Mill, Casa Grande, AZ

Second Place:  
Sharon Hill, WARF Institute, Inc., Madison, WI

**Peanut Aflatoxins (6 samples)**

First Place:  
M. Caerou, Ste. Duquesne-Purina, Montfort-Sur-Risle, France

Honorable Mention:  
Charisse O'Dell, Anderson Clayton & Co., Abilene, TX  
Purina Italia, S.p.A., Treviso, Italy

**Cottonseed Oil (4 samples)**

First Place:  
Doak C. Melear Jr., Southwestern Laboratories, Inc., Fort Worth, TX

Honorable Mention:  
Joseph B. Scheil Jr., Texas Testing Laboratories, Lubbock, TX  
Paul C. Thionville, Thionville Laboratories, New Orleans, LA  
Kenneth Jones, Humko Products, Memphis, TN  
Robert H. Beeler, Levelland Vegetable Oil Inc., Levelland, TX  
Albert M. Reynaud, Charles V. Bacon, Inc., Marrero, LA

**Soybean Oil (4 samples)**

First Place:  
Kenneth Jones, Humko Products, Memphis, TN

Honorable Mention:  
Noal G. Woods Jr., Lever Brothers Co., East Los Angeles, CA  
John W. Thomas, Superintendence Co., Inc., Kenner, LA  
Robert Hein, Dawson Mills, Dawson, MN  
T.M. Narayanan Nair, Charles V. Bacon Laboratories, Jersey City, NJ  
Thomas J. Moore, Woodson-Tenent Laboratories, North Little Rock, AR

**N.I.O.P. Fats & Oils (5 samples)**

First Place:  
John W. Thomas, Superintendence Co., Inc. Kenner, LA

Honorable Mention:  
T.M. Narayanan Nair, Charles V. Bacon Laboratories, Inc., Jersey City, NJ  
Paul C. Thionville, Thionville Laboratories, New Orleans, LA

**Gas Chromatography (5 samples)**

First Place:  
Robert G. Mallning, SCM Glidden-Durkee, Strongsville, OH

Second Place:  
Darwin B. Schlesing, Shedd's Food Products, Detroit, MI

Honorable Mention:  
R.A. Moffitt, Carnation Research Laboratory, Van Nuys, CA  
James A. Laubscher, Woodson-Tenent Laboratories, Memphis, TN  
Daniel C. Esgar, SCM-Glidden-Durkee, Joliet, IL  
C.J. Miller, Rich Products Corporation, Buffalo, NY

**Fish Meal (5 samples)**

First Place:  
Edward R. Hahn, Hahn Laboratories, Columbia, SC

**Honorable Mention:**

John R. Ledin, Woodson-Tenent Laboratories, Des Moines, IA  
Joe C. Bowling, Woodson-Tenent Laboratories, Goldston, NC  
Douglas E. McLemore, Woodson-Tenent Laboratories, Gainesville, GA

**Fish Solubles (5 samples)**

**First Place:**

Earl Louviere, Zapata Haynie Corporation, Reedville, VA

**Second Place:**

Eddie Allen, Louisiana Menhaden Co., Holmwood, LA

**Fish Oil (5 samples)**

**First Place:**

T.M. Narayanan Nair, Charles V. Bacon Laboratories, Jersey City, NJ

**Second Place:**

Robert L. Shelton, Southern Testing Laboratories, Inc., New Orleans, LA ●

**Neumunz to build plant in Iran**

Neumunz, Inc., of Leonia, New Jersey, recently obtained a turnkey contract from the Etko Factories, Tehran, Iran, under supervision of the Iranian Imperial Army to construct a complete 60-metric ton refinery, including hardening facilities.

Neumunz, Inc. is responsible for the engineering, design, and supply of all equipment, including erection of the plant. Start-up date is the end of 1978. ●

**Dr. Downing speaks at Montreal meeting**

AOCS member Donald T. Downing of the Boston University Medical Center presented a paper on analysis of human sebum during the Society of Cosmetic Chemists annual seminar meeting held during May in Montreal, Canada. The paper dealt with what has been learned on the basic biochemistry and physiology of sebum production and excretion, and the effects of age, dietary factors and hormonal status on sebaceous gland activity. ●

**Rothbart cited for beef tallow work**

Dr. Herbert L. Rothbart, acting chief of the physical chemistry laboratory at the USDA's Eastern Regional Research Center, has received the Federal Service Award of the Year 1976 for the Philadelphia area.

The award is presented to recognize exceptional service to the federal government in a scientific field. The award cited Dr. Rothbart's "creative and outstanding leadership of a research team which developed new theoretical and applied approaches in chemical separation culminating in the development of new food materials from the meat by-product tallow." The fractionation of beef tallow has led to materials that may be used as confectionary fats and as cooking oils, both with a significant commercial potential.

The award is sponsored by the Philadelphia Federal Business Association and the Federal Personnel Officers Group.

Dr. Rothbart has been on the ERRC staff since 1966 and is a member of the AOCS. ●

For complete  
**FATTY  
AMINE**  
Plants

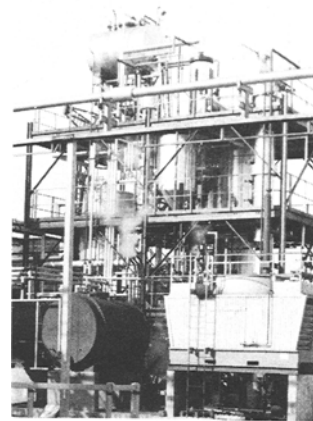

designed and  
built to your  
requirements.

**Peter Jowett & Co. Ltd.**  
CHEMICAL ENGINEERS

Tame Street  
Stalybridge,  
Tameside, England SK15 1QW.  
Phone 061 339 2511 Telex: 669760

also Fatty Acid Hydrogenation  
Edible Oil Hydrogenation  
Fatty Alcohol Manufacture

**French introduces automatic, air-operated roll grinder**

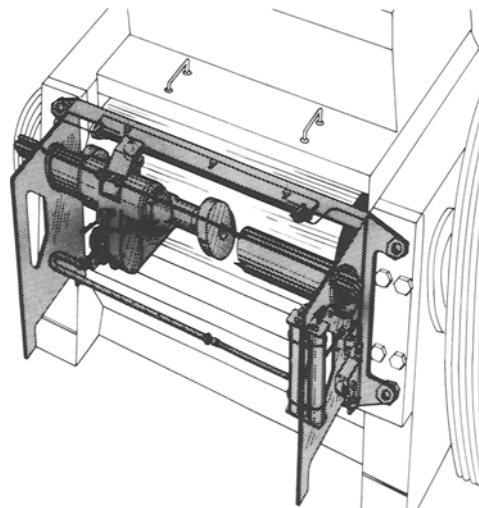

The French Oil Mill Machinery Co. of Piqua, Ohio, has introduced a new automatic, air-operated roll grinder, designed to improve roll refinishing.

The unit, French Oil says, weighs less than other comparable units and is easier and quicker to install, yet does a better refinishing job because "two-wheel, simultaneous action grinds with the circumference periphery of the wheel rather than cross-grinding on the wheel side, thus avoiding objectionable scalloped finish on the roll."

French Oil also says the unit provides consistent, back-and-forth grinder movement across the roll for better refinishing.

Further information is available from French Oil's Solvent Extraction Division, Piqua, OH 45356. ●